

Post size		*W	
in	mm	in	mm
□ 2"	50	96"	2438
□ 2-1/2"	63.5	96-1/2"	2452
□ 3"	75	97	2463

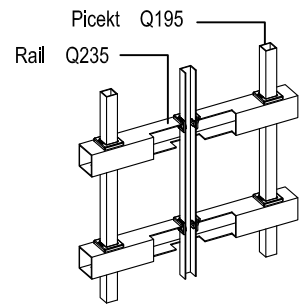

ITEM	Size(mm)	Size(")	Material	Q'Ty	CLIENT
Picket	16*16*1.0	5/8*5/8*19Ga	Q195		
Rail	35*35*1.2	1 3/8*1 3/8*18Ga	Q235		
Post	50*50*1.5	2*2*16Ga	Q235		
Product description					(E)*R**08-S(35N)
Design	A.Z	Standardization	D.FF		
Drawing	D.FF	Approve	A.Z		
Revise	X.G	Date:08-31-2015			
Auditing	M.ZQ				
REVISIONS	DESCRIPTION	DATE	APPRO		

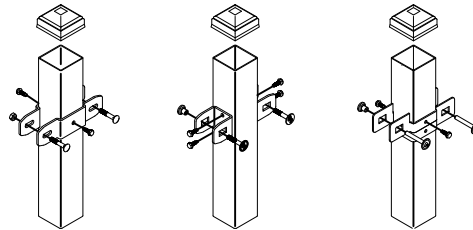
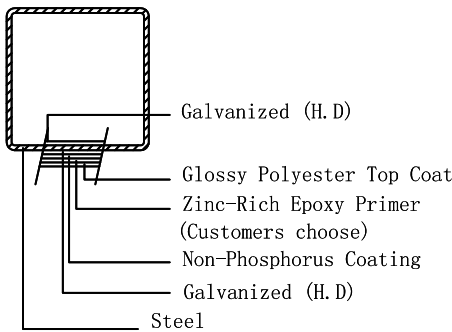
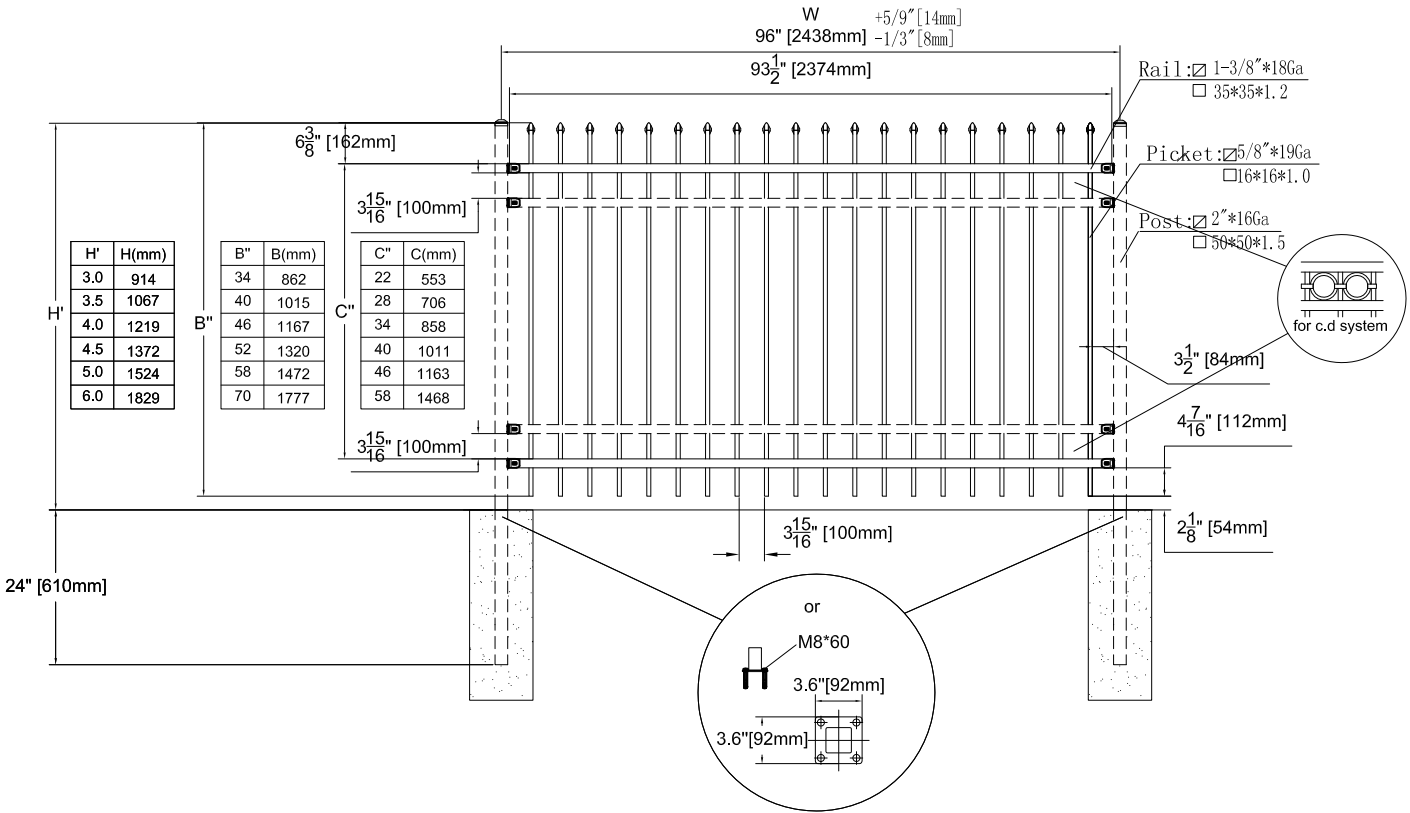

XCEL Fence Inc
 910 E Cedar St.
 Ontario, CA 91761 USA
 Tel: (866)392-0808
 Fax: (909)392-0999
 www.xcelfence.com
 E-mail: info@xcelfence.com